

■ Process: Recycling of old rubber tires



■ The Task

A new production line has been installed in a business which is involved in recycling old rubber tires.

In the initial stage of processing, the old tires are shredded and ground. The ground rubber particles are transported by a current of air. The ground product from the air stream, which in addition to the rubber particles also contains other materials such as fibers and tire cord steel wire, is separated by a cyclone.

The very fine fibrous and electrostatically charged dust from the grinding process and the subsequent separating process must be reliably extracted and removed via a filter system. The composition of this very fine dust places very high requirements on a dust extraction system, which is why the company decided to buy a Herding® filter system.

The conventional filter media used in the past (fabric pocket filters) did not meet the high requirements since the filter fabric quickly became blocked and the dust collected in the hopper.

For the new product line the company required an efficient dust extraction system with a low-wear, rigid-body filter medium to prevent production down times.

■ The Solution

Herding® dust extraction system Type HSL 1500-40/18 GZ

Technical data:

- ▶ Air volume: 20.000 m³/h
- ▶ Fan positioned next to the system
- ▶ Dust is removed on a bucket wheel feeder
- ▶ Residual dust concentration < 1mg/m³!
- ▶ Reliable, low cost dust extraction using the Herding® sinter-plate filter HSL "A"
- ▶ Very long service life of the filter medium due to consistent surface filtration
- ▶ Double plate spacing to prevent the filter medium becoming blocked with fibers
- ▶ Reliable product recovery
- ▶ Small installation area for the dust extraction system

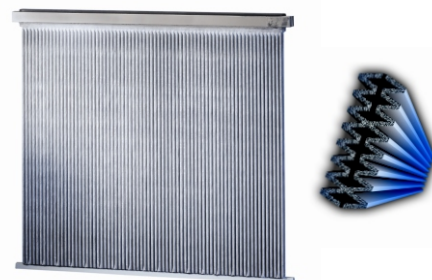

Recycling of old rubber tires

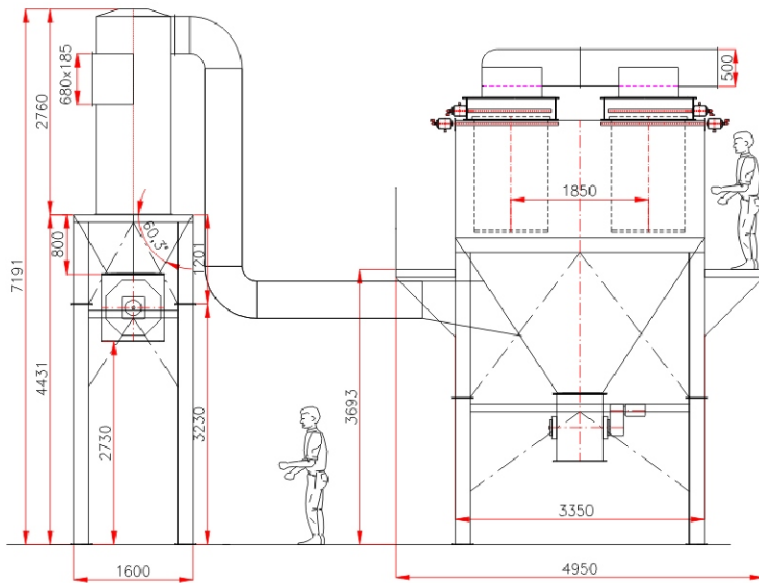

Herding® system: Cyclone + filter unit



Compressed air control valves for cleaning the filter elements with compressed air

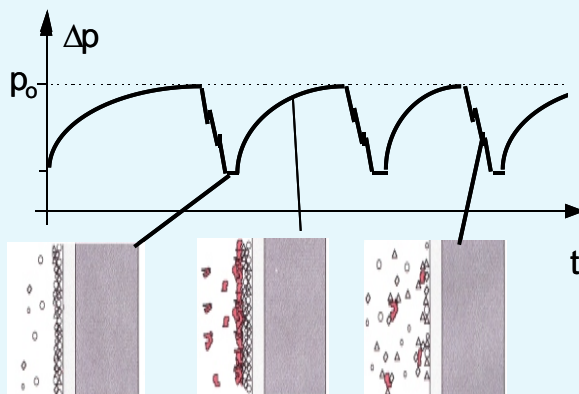

Schematic diagram of the cleaning procedure

HSL "A" filter elements with double element spacing

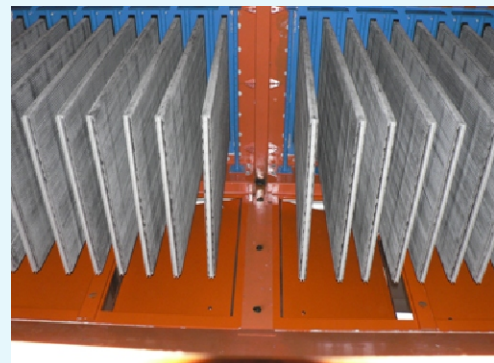

Advantages of the Herding® sinter-plate filters

- ▶ Very high availability due to the long service life of the Herding® sinter-plate filter
- ▶ Residual dust content < 1 mg/m³
- ▶ Low pressure loss due to the relatively large filter area
- ▶ Consistent surface filtration using PTFE coating
- ▶ Special design to order
- ▶ Perfect adjustment of the separating process
- ▶ No production down time

Herding GmbH Filtertechnik
August-Borsig-Str. 3
92224 Amberg/Germany

Telefon: +49 9621 630-0
Telefax: +49 9621 630-120
info@herding.de
www.herding.de